

**BUILT-IN (SINGLE HOLE)**

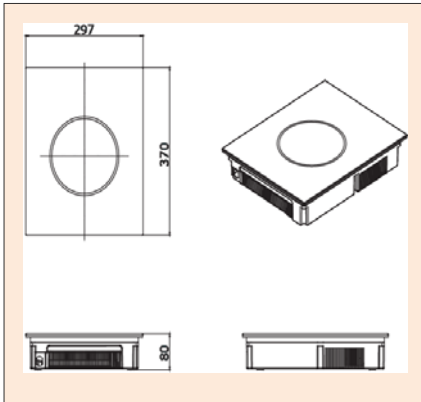

\* Metal Case/ EMC

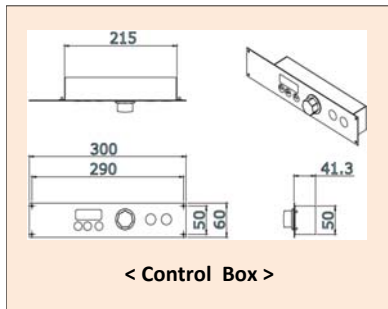

DESCRIPTION				
Part No.	NBK26-E			
Operating Voltage	208/240V , 50/60Hz 1PH			
Power Consumption	Max Output: 2600W			
Amperage	Total: 12A			
Heating Power Setting	Warming: 7 Steps (H1~H7)			
	Cooking: 10 Steps			
Dimension (mm)	Product: 297*370*80 , Packing: 350*505*165			
Weight	6			
Control Method	Separate panel with encoder/ button			
Product Type	Built-in			
Cookware Diameter	Min: $\varnothing$ 130 mm , Max: $\varnothing$ 240mm			
Loadable Weight (kg)	Max. 30			
Time Required for Boiling Water	Capacity	5L (10 portions)	10L (20 portions)	15L (30 portions)
	Burner F	Approx. 13 min 30 sec	Approx. 27 min	Approx. 40 min 20 sec
	Burner B	Approx. 13 min 30 sec	Approx. 27 min	Approx. 40 min 20 sec
Note	※ one portion converted into 500ml ※ start point: 25 °C (room temperature) ※ the abovementioned time can be changed according to actual environment/each different situation			
Main Function	<input checked="" type="checkbox"/> <b>Safety</b> - Over-current indication: Error E1 - Over-voltage indication: Error E2 (above 260V) - Low-voltage indication: Error E3 (below 180V) - Product super-heating indication: Error E4 (internal temperature above 80°C ) - Top overheating indication: Error E6 (above 230°C)			
	<input checked="" type="checkbox"/> <b>Timer</b> - Adjusting in second (range from 1sec through 720min) - One-time setting maintains until being initialized by power button			
	<input checked="" type="checkbox"/> <b>Temperature Mode</b> - Dedicated temperature sensor needed (range from 60°C to 200°C, per 5°C) - Precise temperature adjustment with less than $\pm 2\%$ of deviation (great advantage for fry cooking)			
	<input checked="" type="checkbox"/> <b>Warming: H1 ~ H7 (35°C ~ 90°C)</b>			
	<input checked="" type="checkbox"/> <b>Cooking: 1 ~ 10 (same applies to both of 2 holes)</b>			
Comparison	Item	Induction (1 hole)	City Gas (1 hole)	
	kw	2.6	4.64	
	kcal/h	2241.38	4000	
	kcal/h	2017.242 (90% of efficiency)	2000 (50% of efficiency)	
After-Sales Service	1-year warranty (to be charged in case of consumer's negligence)			

**IMPLEMENTATION**

Application Examples



Product Use

- For various dishes through general cooking, shabu-shabu etc.
- Being utilized in cooking classes thanks to high portability
- As a warmer after cooking

※ Remarks

1. Control Built-in

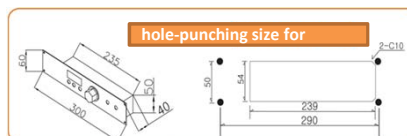

3. Hole-punching size for stainless guide (\*guide sold separately)

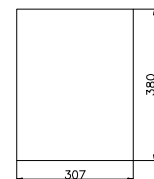

2. Table Built-in (in case of self-bending)

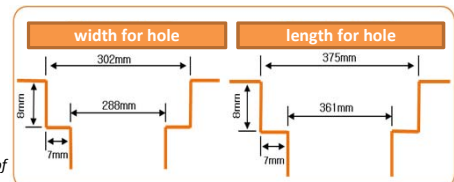

\* Please be advised that it's necessary to keep 10cm of distance from the front/rear side of the unit