

**INSTRUCTION
MANUAL
FOR
DISHWASHING**

Mod. _____

RT200

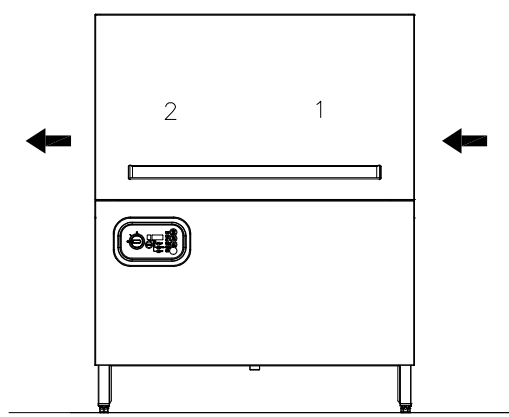

LEGEND

1 = WASH
2 = RINSE

HEATING

- ELECTRIC
- STEAM
- _____

OPTIONALS

- | | |
|---|---|
| <input type="checkbox"/> DRYER | <input type="checkbox"/> SPLASH HOOD |
| <input type="checkbox"/> STEAM CONDENSER | <input type="checkbox"/> SPLASH HOOD WITH COLLAR |
| <input type="checkbox"/> HEAT RECOVERY UNIT | <input type="checkbox"/> SPLASH HOOD WITH VENT DUCT |
| <input type="checkbox"/> DRAIN WATER HRU | <input type="checkbox"/> LIGHT PREWASH "DETREMPE" |
| <input type="checkbox"/> SANITIZING SYSTEM | <input type="checkbox"/> _____ |
| <input type="checkbox"/> AUTOTIMER | <input type="checkbox"/> _____ |
| <input type="checkbox"/> RINSE BOOSTER PUMP | <input type="checkbox"/> _____ |

TOTAL POWER	_____	kW
ELECTRICAL ABSORPTION	_____	A
CABLE DIMENSIONS	_____	mm ²
NOMINAL CURRENT OF THE MAIN CIRCUIT BREAKER (In)	_____	A
SHORT CIRCUIT CURRENT OF THE MACHINE: I _{cc} = 6kA		

INDEX

Introduction	5
INSTRUCTIONS FOR USE	7
Notes before washing	8
<i>Operation and use</i>	8
Switching on	8
Washing.....	9
Instruction during washing	9
Instruction after the washing session.....	10
Useful advice	10
Maintenance	10
Hygienic care	11
Removal of lime scale encrustation's	11
<i>Optimum results</i>	11
Prolonged standstill of the machine.....	11
Self cleaning (optional)	12
<i>Safety device</i>	12
Micro limit switch SS1	12
Doors micro switches SS2...SS20.....	12
Emergency stop push-button S3	12
Slip clutch	12
Motor protection.....	13
Element protection.....	13
Other risks	13
Risk of trapping the upper limbs	13
Risks of burning the upper limbs	13
INSTRUCTION FOR INSTALLATION AND MAINTENANCE	14
Location	15
Installation and connections	15
Electrical connection.....	15
Hot water connection (B)	17
Cold water connection (D)	17
Steam connection (E) (only for steam heated machines).....	17
Water drain (A)	17
Steam discharge (F) (only for steam heated machines).....	17
Steam elimination	18
Before starting the machine.....	18
Setting	19
Torque limiter.....	19
Alarms	19
Loading and unloading of the machine.....	19
Machine dismantling	19
Some problems which may occur during the use of the dishwasher, their reasons and remedies	20

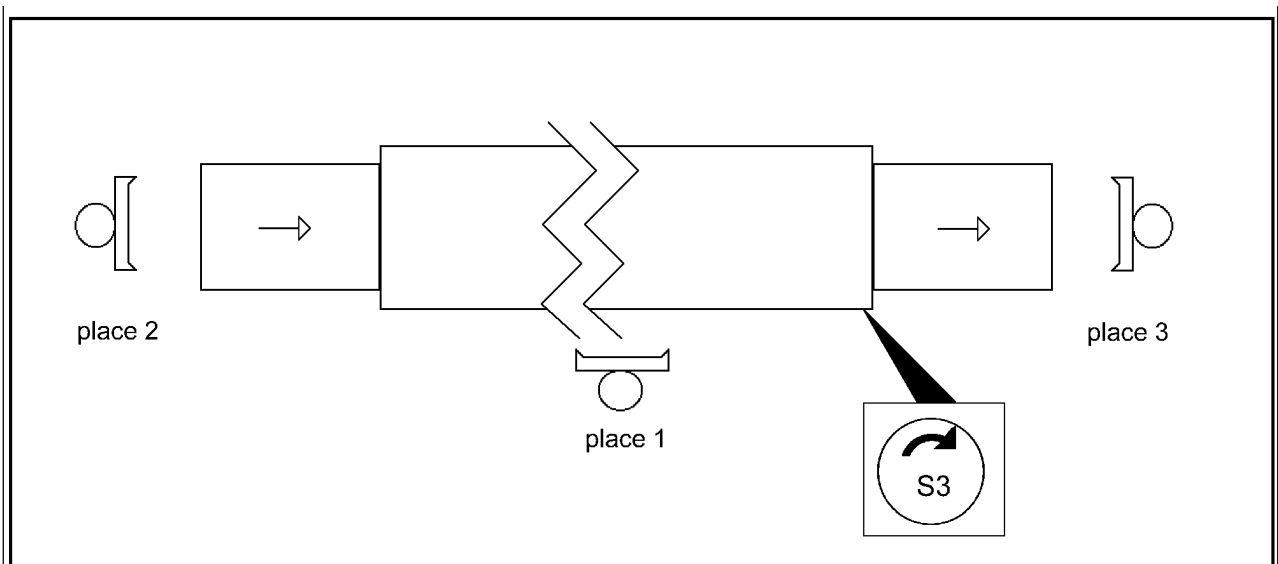

INTRODUCTION

1. Please read carefully the remarks contained in this manual, as they confirm important information for the correct installation, use and maintenance. Keep this manual for future reference by the staff.
2. After removal of the packing, check the machine is not damaged and is complete. In case of any doubt, do not use the machine and contact the service technician. The packing case (plastic bags, expanded polystyrene, nails etc.) must not be left on site as they are a potential danger source and must be disposed of carefully.
3. Before connecting the machine to services, check that the details on the data plate correspond to the services provided on site.
4. The installation has to be completed by qualified staff in accordance with all relevant regulations and the manufacturers instructions.
5. This machine must only be used for the purpose designed: washing of dishes such as plates, glasses, cups, cutlery, trays etc. Any other use such as washing of machine parts or objects with higher dimensions than the working passage of which the machine allows is not recommended and will cause damage to the machine and danger to the operators.
6. The machine must be used only by trained staff.
7. The staff handling the objects after the washing cycles must comply with hygiene regulations.
8. Do not keep the machine in places with temperatures below 0°C.
9. The protection degree of the machine is IPX4 and it must therefore not be washed with direct water jets at high pressure.
10. After isolating the electrical supply, only qualified staff are allowed access to the control panel.
11. The machine is built according to I.E.C.-standard 89/336 relating to the elimination of radio interferences and to the electromagnetic compatibility.
12. In conformity with I.E.C.-standard our dishwashers are manufactured according to the standard of excellent technical level valid in Italy and abroad.
13. Noise of empty machine operation, measured at the working places (fig. 1) at 1.6 m height, are as follows:

	place 1	place 2	place 3
LeqA level equivalent to the acoustic pressure dB(A)			

The peak of the acoustic pressure level is not indicated, as far below 130dB(A):

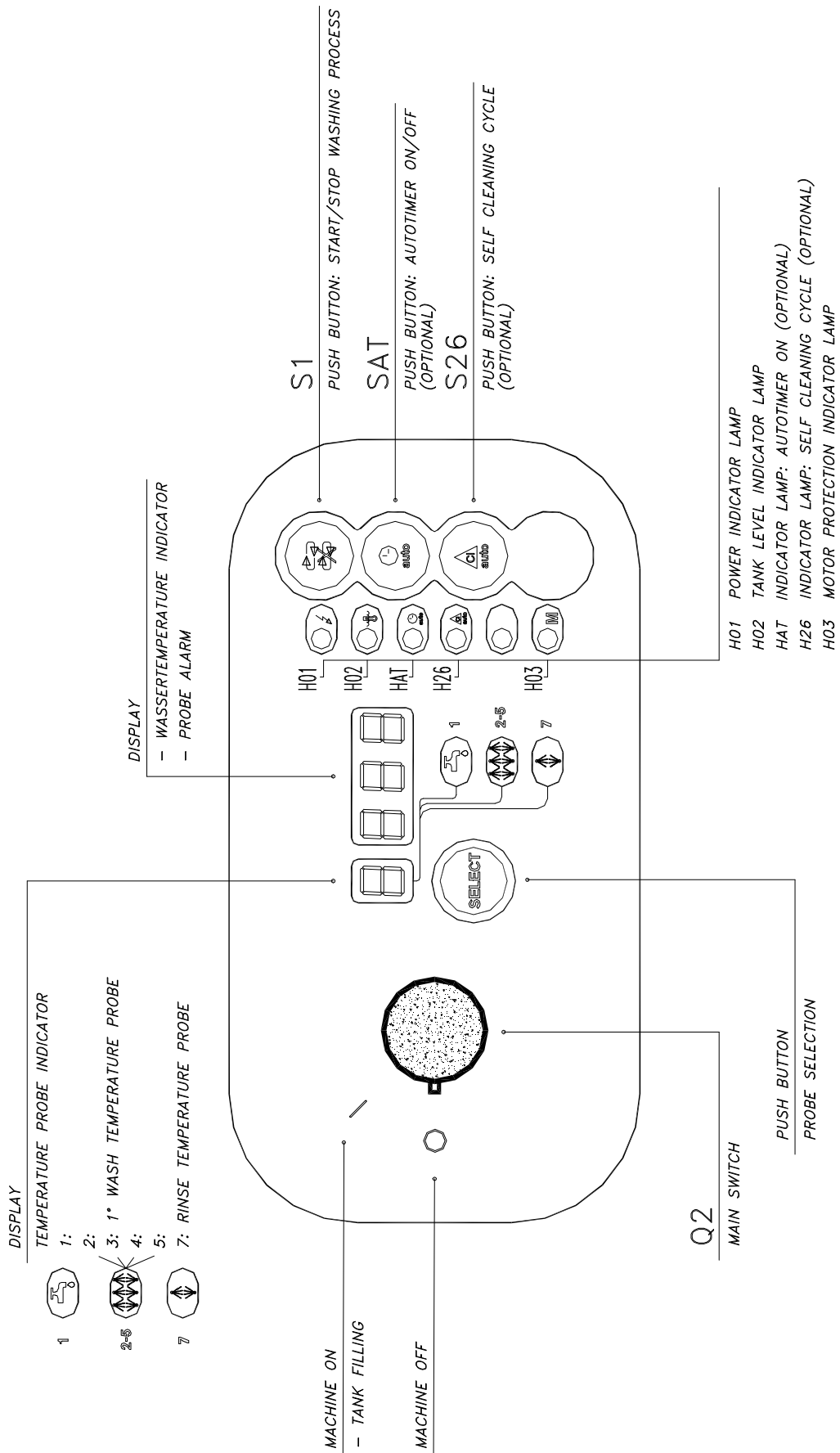

INSTRUCTIONS FOR USE

NOTES BEFORE WASHING

1) Make sure that:

- wall isolating switch is connected
- water and steam taps* are open
- there is no lack of water and steam* in the supply net
- tank and pump suction filters are clean and are located correctly
- curtains are correctly placed
- inspection doors are closed
- detergent and rinse aid dispensers are full
- dimensions of the dishware do not exceed those prescribed

OPERATION AND USE

Switching on

In order to turn the machine on simply rotate the main switch "Q2" to the right on to position "I". Lamp "H01" will illuminate.

Close all machine doors.

Wait for lamp "H02" to turn on indicating tank is full.

Every time the button "SELECT" is pushed the display show:

- 3:** wash temperatures probes (55-60°C);
- 7:** rinse temperature probe (80-85°C).

Wait until the wash tank temperature reaches 55/60°C; at this point the machine is ready for use.

Push switch "S1" to start or stop washing process.

The lamp "H03" indicates that the pump is overheating, technical assistance required

Push switch "SAT" to start the autotimer function; lamp "HAT" will illuminate.

The **autotimer** function with **automatic reset** temporarily stops the operation, if no racks have been introduced into the machine. Placing a rack into the machine, this restarts automatically.

(*)this applies only to machines with steam heating

WASHING

- 1) Before starting the wash operations remove from the dishes all possible food leftovers and grease.
- 2) Pre-soak cutlery and also any dishes before washing, if they have been left for some time after being used.
- 3) Place the items to be washed in the baskets.
- 4) Make sure that the plates are turned towards the exit of the machine.
- 5) If the operator using the machine does not remove the racks from the exit table, a limit switch ensures the conveyor and rinse cycle is stopped. Removing the rack from the limit switch re starts the washing sequence.

INSTRUCTION DURING WASHING

- 1) Do not put your bare hands in the hot and detergent water in the tanks, as this may cause burns and skin irritations. Should this happen rinse your hands immediately under fresh water.
- 2) When the machine is functioning do not open inspection doors quickly.
- 3) Use only commercial non-foaming detergents for industrial dishwashers, supplied by well-known and reputable companies.
- 4) Isolate the electrical supply to the machine in the case of a breakdown or defective operation. For all repair work, rely exclusively on a Technical Assistance, approved by the manufacturer and request that original spare parts be used.
- 5) At periodic intervals stop the machine, remove tank filters and remove the residues which have accumulated. Do not remove the pump suction filters when the tank is full. For machines equipped with the light prewash, remove and clean also the basket filter fit in the hood.
- 6) If the rack advancing system has stopped due to the safety device (slip clutch) operating, stop the machine by pressing the mushroom-shaped emergency push-button "S3" and remove the obstruction which caused the problem.
- 7) Ensure the detergent and rinse aid levels, in the respective dispensers are kept topped up.
- 8) Make sure that water temperatures maintain their regulated values:
wash (probe 3) 50/60°C, **rinse** (probe 7) 75/85°C.

The non-observance of the above mentioned points may compromise the safety of the machine and the staff.

INSTRUCTION AFTER THE WASHING SESSION

When the wash operations are complete:

1. Press button "S1" and turn switch "Q2" into position "O" to switch off the machine.
2. Isolate the machine by means of the wall switch and close the water valve and steam supply (this applies only to steam heating machines).
3. Lift the inspection doors and make sure that they are perfectly hooked onto the support.
4. Press the drain process button to empty the tanks.
5. Take out the anti -splash curtains and the filters for cleaning.
6. Check and, if necessary, clean the wash and rinse nozzles. Clean out the wash tanks with a wash spray hose assembly.
7. For machines with a steam condenser remove the steam suction filter for cleaning (fig. 3):
8. Clean the external surface of the machine with a damp cloth; do not use jets of water, as, apart from being dangerous, damage to electric components may occur; do not use abrasive detergents or those containing chlorine.
9. Reassemble all devices into their locations, taking care that:
 - the curtains are turned with the short side towards the entry of the items being washed
 - the wash nozzles are turned towards the items being washed
10. Keep doors open in order to avoid unpleasant odours, when not in use.

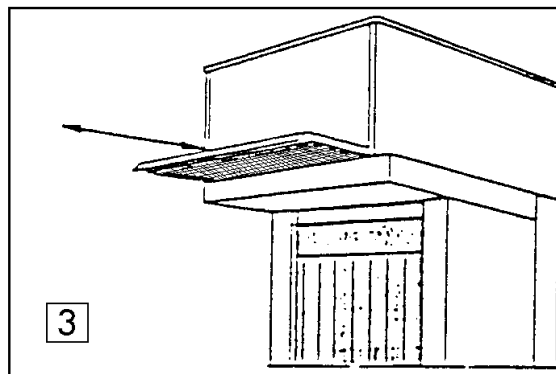

USEFUL ADVICE

Maintenance

IMPORTANT: Before undertaking cleaning and maintenance work, isolate the machine from the electric supply by switching off the wall switch.

Regular check and cleaning of the nozzles is advisable. The frequency of cleaning depends on the quantity of leftovers and foodsoiling left on the crockery, insufficient cleaning of nozzles will give poor wash results. Do not use corrosive products such as hypochloride sodium (bleaching products), acids in general, steel wool and steel brushes for cleaning the machine inside and outside.

To ensure the machine is kept in a perfect hygienic condition, it is advisable to carry out the following periodic operations.

Ensure the procedures and frequency recommended by the detergent supplier are followed, also ensure that the correct products and equipment are used. In order to avoid damages to the machine, do not exceed the recommended dosing and at the end of the procedures, rinse thoroughly.

Hygienic care

A thorough cleaning of the machine is essential. For this operation the use of sanitizing detergent/disinfectant is advisable. The use of such a product offers the following advantages:

- guarantee for perfect hygienic conditions, as it is composed of active detergents and disinfectants.
- maintenance of perfect hygienic conditions, also if the machine is not used.

After completion of above procedures the machine has to be rinsed by completing a short washing cycle without load or by using the sanitizing cycle (optional).

Removal of lime scale encrustation's

In case of hard water a periodic descaling should be carried out to ensure hygiene and proper operation.

Optimum results

Traces of dirt or marks are the result of a possible deficiency in the wash operation. If this problem occurs ensure that the wash nozzles are clean and that there is an adequate water supply/pressure available. Also check the following points

- wash nozzles are not blocked
- water supply temperature is 50/55°C (excluding machines with heat recovery unit or machines functioning with cold water feed)
- wash temperatures (probes 3) is 55/60°C
- rinse temperature (probe 7) is 80/85°C
- detergent is used in the correct concentration
- filters are clean
- water is not too dirty
- dishes are not stacked one upon or inside the other, as the water needs to circulate freely and directly contact all surfaces.

Prolonged standstill of the machine

In case of a prolonged standstill lasting several weeks it is advisable, in order to avoid unpleasant odours and the accumulation of dirt, to empty the machine, refill and run with clean water.

If the standstill lasts for a very long time, it is recommendable to lubricate the stainless steel surfaces with Vaseline oil.

Self cleaning (optional)

At least once a week a thorough cleaning of the machine is necessary. For this purpose a specific detergent/disinfectant is advisable. The use of such a product offers the following advantages:

- guarantee of perfect hygienic conditions as it is composed of active detergents and disinfectants
- maintenance of the machine in perfect hygienic conditions, also if the machine is not used.

For starting the self cleaning sanitizing cycle, switch "Q2" has to be put into position "O". Empty the tanks by the drain process, remove the curtains, close the inspection doors and press push-button "S26". The lamp "H26" is illuminated during the whole period of the cycle.

SAFETY DEVICE

This machine is provided with numerous devices for ensuring the safety of the staff and the machine.

Micro limit switch SS1

When the rack reaches the end of the exit table, the limit switch operates and stops the conveyor and consequently the breaking of the crockery. By removing above, the conveyor automatically restarts.

Doors micro switches SS2...SS20..

The door is provided with one safety micro switch.

If the doors is opened, the functioning of the pumps, the motor reduction gear of the conveyor unit and the rinse solenoid valve are interrupted. The operation is resumed only after the doors are closed again and by pressing the start push-button "S1". In case of dishwashers with a complex lay-out, several push-buttons near the working stations may be necessary.

Emergency stop push-button S3

The machine is provided with an emergency red mushroom-shaped push-button on yellow background which easy accessible from operator, if pressed, stops all motors on the machine. After elimination of the problem, the machine can only be started after turning and releasing the push-button and pressing again the start push-button "S1". In case of complex lay-out more push-buttons may require releasing near the work stations.

Slip clutch

The rack conveyor system is provided with a clutch-type mechanical torque control, which is fitted to the drive mechanism of the conveyor system. If something gets erroneously jammed in between the machine and rack or the rack is overloaded, the conveyor system quickly slows down to nearly zero. In this case it is necessary to switch off the machine by means of stop or emergency push-buttons, remove the obstacle and press again the start push-button. For adjustment of this safety device refer to paragraph MAINTENANCE.

Motor protection

Each motor is protected against overload by overload relays **QF1, QF2...** placed in the control box (see electric diagram).

Lamp "**H03**" is on, if one of the overload relays is activated. In this case the machine must be switched off and qualified staff are to be contacted for the repair work. (see paragraph MAINTENANCE).

Element protection

Each element is protected against short-circuits by the fuses (**FE3..**) or with automatics (**QFE10**). The tank elements are protected against operation without water in the tanks, by pressure switches and those in the boiler and dryer by safety thermostats which have to be manually reset.

In case of intermittent problems contact qualified and authorised staff. (see paragraph MAINTENANCE).

Other risks

Although the machine is provided with the above mentioned safety devices, there are still the risks listed below.

Risk of trapping the upper limbs

As previously pointed out above, the conveyor system is provided with a clutch-type mechanical torque control, the adjustment must be related to the mechanical torque required for the transport of the items being washed.

The mechanical risks of trapping the upper limbs have been eliminated by protecting and isolating the dangerous moving parts. When the machine is operating do not introduce your arms into the wash tunnel.

Risks of burning the upper limbs

Under the paragraph INSTRUCTION DURING THE WASHING we have previously advised that you must not put your hands into the hot and detergent water of the tanks. This might cause burns and skin irritations. In case this should happen immediately rinse under fresh water and follow the instructions of the product being used.

INSTRUCTION FOR INSTALLATION AND MAINTENANCE

The following instructions are for qualified staff, who are authorised to carry out inspections and repair work, if necessary.

The manufacturer declines all liability for damages due to incorrect installation or any repairs when original spare parts have not been used.

LOCATION

The machine has to be installed in a “normal” room or environment, which is adequately ventilated, dust free, well illuminated and without risk of explosion.

INSTALLATION AND CONNECTIONS

The installation of the dishwasher requires previously prepared supplies for the electrical and hydraulic connections, as indicated on the enclosed installation plan and data plates which refer to the model of your choice.

In order to prevent damage due to the emission of steam from the machine, ensure that adequate ventilation/extraction is available.

Remove lower panels and position the machine over service connections. Fit the standard rubber absorbers supplied under the adjustable feet of the machine and adjust them to level it, if necessary.

Connect the load and unload tables. It is advisable to fit a table crowding switch "SS1" on the unload table. For the electrical connection, see fig.4.

The supplier of detergents has to provide the required dispensers.

Attention: The supply of detergents and hygienic products should be provided by the use of automatic dispensers, as it is not possible to obtain adequate quantities, when pouring the detergent directly into the tank. There is also the risk that brown spots may appear on the surfaces due to the reaction of chloride.

The introduction of the detergents must take place near the suction tube of the pump, the minimum distance from the bottom must be 15 cm in order to avoid corrosion.

ELECTRICAL CONNECTION

The electrical supply voltage must correspond with the machines electrical requirements, as indicated on the machines data plate

Electric supply has to be isolated via a wall mounted three-pole circuit breaker with opening distance of the contacts 3 mm or more. For the dimensions of above refer to the “Technical data sheet” on page 1 of this instruction manual.

The section of the supply cables must not be inferior to that indicated in the “Technical data sheet”. If the cable is not protected use a flexible cable with protective covering in polychloroprene with characteristics matching at least type H07RN-F.

The cable must be connected to the terminal “PE” of the grounding bar.

The electrical safety of this machine is guaranteed only on condition that it is connected as follows.

It is necessary to connect the machine to an efficient grounding system as required by the current electrical standards in force at the time of installation. Check this basic requirement and in case of any doubt, request that a thorough check of the system be carried out by qualified electrical staff.

The machine must be included in an equipotential system, whose efficiency has to be checked according to the valid standard. The connection is made by means of a screw with the identification ∇ fitted to the back of the machine.

The manufacturer declines all liability for damages due to the lack of an efficient earth bonded installation.

For the electric connection of the detergent dispensers the machine is provided with two connections in the electric board marked "**DD**" connected to the wash pump. The use of these connections is essential to avoid damages to the electrical components of the machine, as there are consequently no flying connections in other areas.

For the connection of the rinse aid dispenser, the machine is provided with two connections in the electric board marked "**BB**" connected to the rinse.

Please remember that the voltage of the connectors "**BB**" and "**DD**" must correspond to that of the supply.

Maximum allowable absorption 1A.

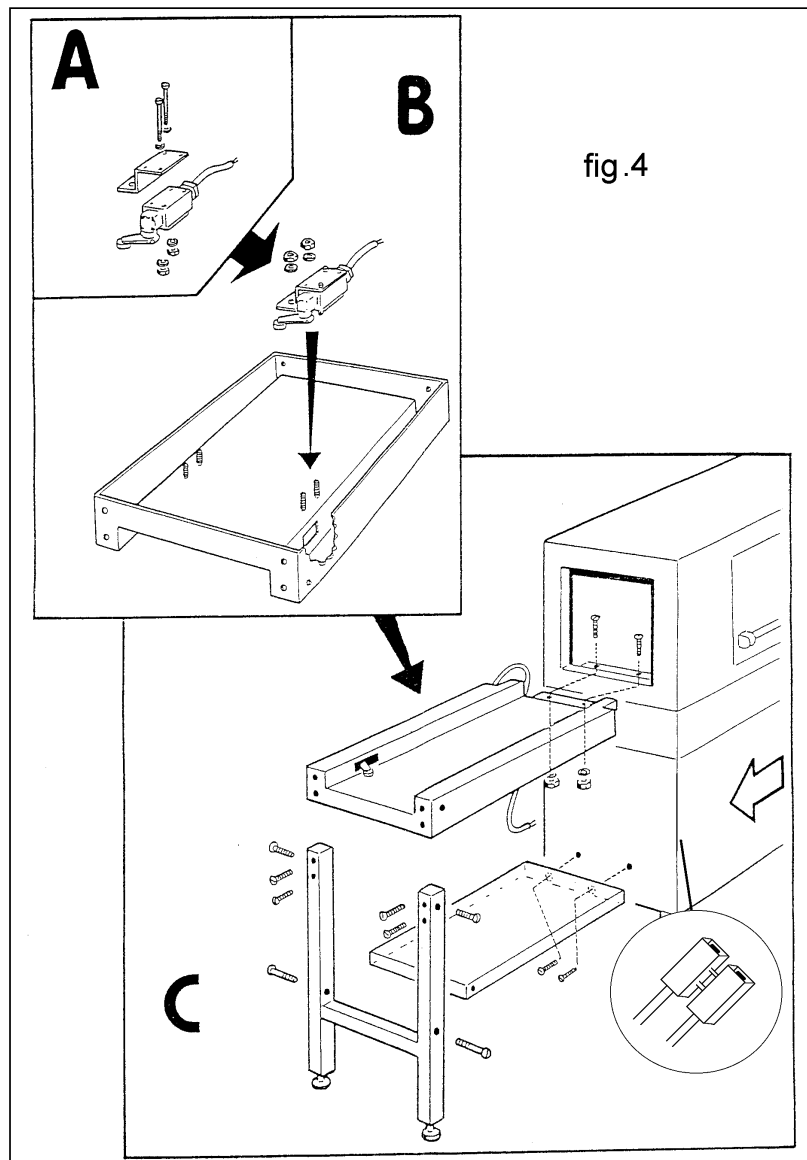

HOT WATER CONNECTION (B RED)

A water valve has to be provided in an easily accessible position, to which the inlet filter has to be connected. For dimensions of the valve please refer to installation drawing.

Strictly observe the national and regional water board regulations in force.

The dynamic pressure must not be less than 2 bar and not more than 4 bar (200/400 kPa). A good result can be obtained if the incoming water has a hardness not exceeding 5/7°Clarke and a temperature of 55°C-0+10°C.

The correct quantity of rinse water is regulated by the flow restrictor of solenoid valve Y10.

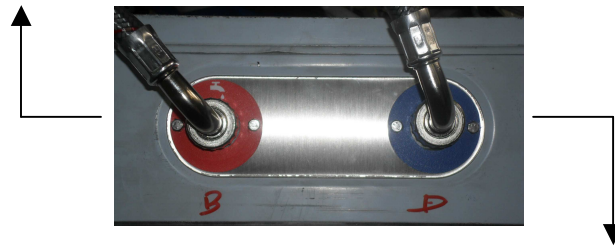

COLD WATER CONNECTION (D BLUE)

A water valve has to be provided in an easily accessible position, to which the inlet filter has to be connected. For dimensions of same please refer to installation drawing. Strictly observe the national and regional water board regulations in force. The working pressure must not be less than 2 bar and not more than 4 bar (200/400 kPa). Only for machines steam energy recovery unit, for obtaining a good result the incoming water should have a hardness not exceeding 5/7°Clarke.

STEAM CONNECTION (E) (only for steam heated machines)

The supply of steam and connections to the machine must be in accordance with the installation drawing. In order to isolate the machine from the general steam supply network it is essential to provided a local isolating valve of 1" BSP.

The minimum pressure for the steam supply is 0,5 bar (50kPa-110,8°C) and the maximum pressure is 1,5 bar (150 kPa-127°C). If especially requested in the order the maximum pressure can reach also 3bar (300 kPa - 143°C). The steam must be absolutely saturated and dry.

WATER DRAIN (A)

A floor drain with a waste trap has to be provided for connection to the machine, make sure that there are no restrictions in the waste service. Any materials used on the installation must withstand a temperature of 70°C. Strictly observe the national or regional water board regulations relating to water discharges.

STEAM DISCHARGE (F) (only for steam heated machines)

The discharge of the steam condensate must have a suitable inclination towards the recovery system or recirculation pump which guarantees the automatic removal of the condensate.

STEAM ELIMINATION

For machines with splash-guard protection with collar or machines with heat recovery unit, connections are to be effected according to fig.5.

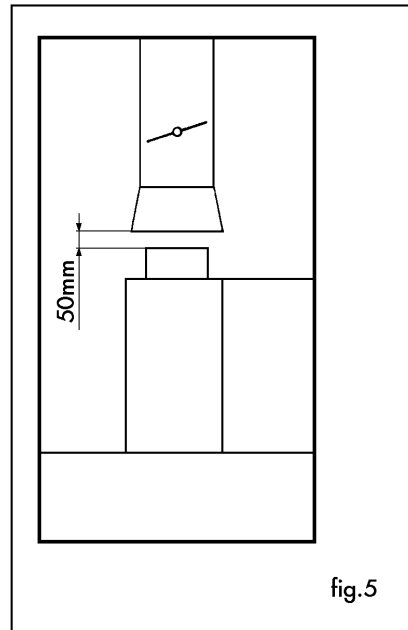

BEFORE STARTING THE MACHINE

- The boiler circuit breaker **QFE10** (and **QFE11**) has to be open (position OFF). Before reactivating it, check, after having switched on the machine that the boiler is full of water by making sure that water is coming out of the rinsing nozzles.
- Make sure that all motors turn in the right direction; generally this can be taken for granted if the arrow on the drive assembly turn in the right direction (fig.6).

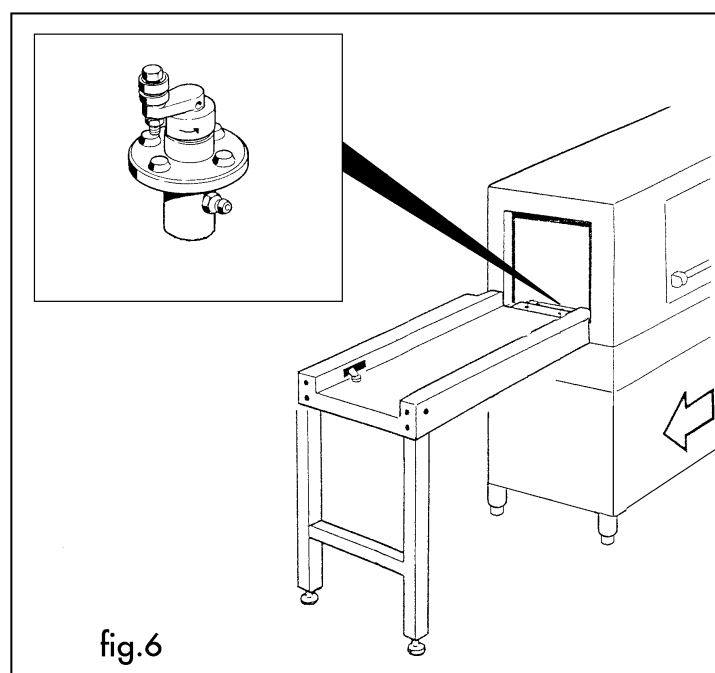

SETTING

Torque limiter

The limiter has already been described in paragraph "SAFETY DEVICES".

It is placed on the drive shaft and is adjusted during the commissioning of the machine. Should new adjustments be necessary, proceed as follows:

- 1) Switch off the machine
- 2) Remove protective panel
- 3) Load the exit table with full dishes racks up to approx. 50 cm from the end run switch
- 4) Loosen the clutch until it succeeds in transporting the racks.
- 5) Adjustment is considered correct, when the drive just succeeds in transporting the total load up to the extreme end of the exit table after pressing the "S1" push-button.

ALARMS

The display show:

A2 probe (1...7): temperature over 105°C or probe in short circuit

A3 probe (1...7) not connected

LOADING AND UNLOADING OF THE MACHINE

For the transportation of the machine from the delivery point to the final installation position, use a fork lift or adequate lifting equipment used by authorised staff. Lift the machine by its frame, taking care that any protruding parts are not damaged (discharges, wiring etc.).



MACHINE DISMANTLING

At the end of its normal lifetime, the machine has to be taken apart according to the local regulations in force by separating the components as follows:

- metal parts: hood, platforms, frames, filters
- electrical parts: motors, remote control switches, microswitches, wiring
- plastic parts: racks, connections
- rubber parts: tubes, sleeves

SOME PROBLEMS WHICH MAY OCCUR DURING THE USE OF THE DISHWASHER, THEIR REASONS AND REMEDIES

PROBLEMS

TROUBLE SHOOTING

When switching on the machine,
Lamp "**H01**" does not light up

a)make sure that the wall isolating switch is making contact and the relevant fuses are not burnt.

b)make sure that the wall switch is connected

c)make sure that the fuses "**F15**" and "**F16**" of the transformer "**T1**" are not burnt.

Warning lamp "**H03**" is switched on

a)check the overload and contactor of each motor and reset any which have tripped

b)make sure that the supply doesn't fluctuate more than 6% of the nominal value

c)make sure that the motors are not drawing more current than the value shown on the plate of the motor

d)make sure that there are three phases to the motors If not, check the contactor

Incorrect filling of the tanks;
lamp "**H02**" does not illuminat

a)Check and adjust the pressure switch "**SL3**" if required

b)make sure that the local isolating valve for the water supply is open and that there is water in the supply pipes

d)make sure that the coil of the solenoid valve for the tank fill is not damaged and that there is voltage at the valve

Continuous filling of tanks

a)make sure that the air trap of the pressure switch is not damaged and that the connection to the hose is not detached.

b)check the pressure switch operates correctly

PROBLEMS

TROUBLE SHOOTING

c)make sure that no dirt has accumulated in the solenoid valve. This defect causes the machine to fill also when the main switch is switched off.

d)in case the tank remains full for many hours (e.g. during the night) the machine might continue to fill. Therefore empty the machine completely and refill it.

e)check that the air trap is in a vertical position.

Insufficient wash results

a)make sure that detergent equipment is working and is suitable for commercial dishwashers and that the concentration of the dosing is correct

b)make sure that the dispenser of the detergent is not empty and that the detergent injector functions correctly

c)make sure that the wash jets are not blocked, clean them if required.

d)make sure that the temperature in the prewash and wash tank are correct.

e)make sure that the plugs of the spray arms are fitted correctly

f)if the pump is not running; check the following:

- the overload relay of the motor protector has not excluded the respective pump; in this case reset it (this fault is signalled by the lamp "**H03**" being illuminated)

- the coil of the relevant contactor are not faulty

- the pump itself is not blocked, and is not going in the wrong direction or has a worn or broken impeller.

PROBLEMS

TROUBLE SHOOTING

Insufficient tank temperature

a)make sure that the thermostat is not damaged.

b)make sure that the water supply temperature is as prescribed (50/55°C)

c)check that the fuses and the coils of the contactor relating to the heating elements are not interrupted (only for machines with electric heating).

d)check the elements are heating and that no limescale deposit has formed.

e)for machines with steam heating check the steam solenoid valves, the steam traps are clear and the steam pressure at the machine. Check the installation of the condensate recovery by detaching the discharge tube of the steam condensate and discharge it into an open drain.

If the pressure at the manometer is 0,5 bar min. and the machine starts heating, this means that the problem is on the installation of the steam condensate recovery.

Insufficient rinsing

a)Before checking the rinse system check that the wash section is operating correctly, as poor wash results may affect the efficiency of the rinse. Once the efficiency of wash area has been checked make sure that:
- the dynamic pressure of the water supply is not less than 2bar (200 kPa).

b)the nozzles are not blocked by limestone

c)the solenoid valves "**Y10**" and is operating correctly.

d)the filter of the incoming water is not blocked.

PROBLEMS

TROUBLE SHOOTING

Insufficient rinse temperature

e)the boiler is not encrusted in any way as to limit the water flow.

a)make sure that the temperature of the supply is that prescribed 50/55°C.

b)make sure that the thermostat "ST10" is adjusted to the correct temperature.

c)make sure that the thermostats "ST10" and "ST10A" are not faulty

d)make sure that the rinsing nozzles have not been incorrectly increased or replaced by another type.

If none of the above reasons appears to be the cause for the problem, proceed as follows:

Machine with electric heating

Make sure that the circuit breaker "QFE10" (or QFE11)has not switched off or is faulty.

make sure that the coil of the contactor "KE10" (or KE11) is not interrupted.

check all sections of the boiler elements "E10" (or E11).

make sure that the safety thermostat "ST10A" (or ST11A) has not operated. Should this have happened check the reason, then reactivate it as well as the circuit breaker "QFE10" (and/or QFE11)

PROBLEMS

TROUBLE SHOOTING

Machine with steam heating

make sure that the steam valve is open and that there is steam at a pressure not less 0,5 bar (50 kPa)

make sure that the filter of the condense trap is not blocked

make sure that the steam solenoid valve "YV10" is working.

make sure that the filter of the steam strainer is not blocked, thus restricting the normal flow of steam.

make sure that the steam condensate is being discharged freely.

make sure that the steam heating coil is not encrusted, thus limiting heat exchange.

The manufacturer declines all liability for printing errors in this instruction manual. He furthermore claims the right to carry out modifications which are useful for his products without compromising their essential features.

CE