

Rack conveyor dishwashing machine – RT 200 -30

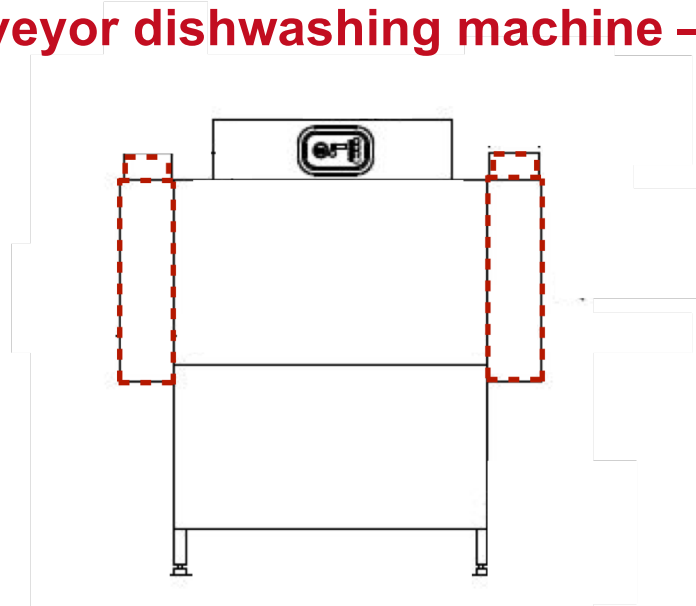

Brief description

Single tank rack conveyor dishwasher.
1150 mm Upper/Lower Wash and single rinse with DIGIT control panel with digital temperature display and diagnostic.

Counterbalanced Insulated doors.

Key features

Rack Production 200 rack/hour
Rinse water consumption 320 l/h
Tank capacity 80 liters
Total length 1150 mm

Power supply 400V 3N~
Frequency 50/60 Hz
Unit connection load (cold water) 43,03 kW ●
Sensible capacity 4,4 kW
Latent capacity 6,2 kW

Standard features

- AISI 304 stainless steel tank chassis and paneling
- Inspection doors with integral balancing springs
- Compact installation dimensions
- Stainless steel upper and lower inspectable washing manifolds with negative embossed anti-drip nozzles
- Deep-drawn tanks with rounded corners
- Self-draining vertical pumps
- Door wipe seal for constant cleaning of the inside of the door
- Whole tank stainless steel filter and pump suction filter
- Color Coding - Each module of our tunnel machines is identified by a color, as well as its internal components. This helps for cleaning operations and machine preparation process, avoiding incorrect combinations and malfunctioning.
- Electronic control panel with digital display temperature readout
- Double-wall doors
- 24V control circuit
- Economizer that activates rinsing only when rack passes through
- Electrical setup for connection of dosing devices for chemicals
- Machine side disconnection switch
- All prewash sections with inspection door

Standard configuration

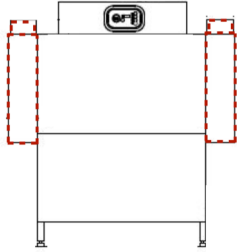

Wash

In this zone food residue is removed thanks to the combined action of detergent and large circulation pump.

Module length	1150 mm
Wash pump	0,85 kW
Tank heater	12 kW
Tank volume	80 l

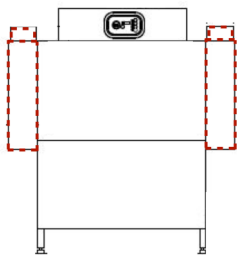

Rinse

In this zone, the dishware is rinsed with fresh hot water.

Rinse water flow consumption	320 l/h
Booster heater (@ 15°C)	30 kW ●

Accessories

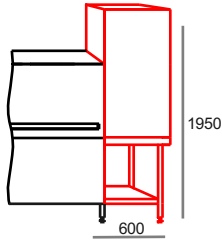

AS6 - 600 mm Blower Dryer

The air for the dryer is heated in a battery with heaters and blown on the dishware by means of a double jet.

Module length	600 mm
Dryer fan power input	0,42 kW
Dryer heaters	6 kW
Sensible Capacity	8,2 kW
Latent Capacity	8,6 kW

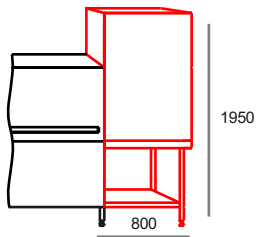

AS8 - 800 mm Blower Dryer

The air for the dryer is heated in a battery with heaters and blown on the dishware by means of a double jet.

Module length	800 mm
Dryer fan power input	0,42 kW
Dryer heaters	6 kW
Sensible Capacity	8,2 kW
Latent Capacity	8,6 kW

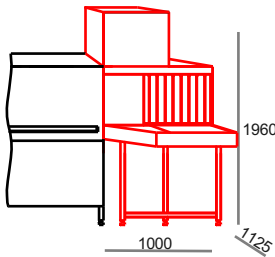

TC90 - AS Blower Dryer on 90° exit curve without motor

The dryer is fitted on a 90° mechanized curve to optimize working space in the washing area.

Module length	1000 x 1125 mm
Dryer fan power input	0,42 kW
Dryer heaters	6 kW
Sensible Capacity	8,2 kW
Latent Capacity	8,6 kW

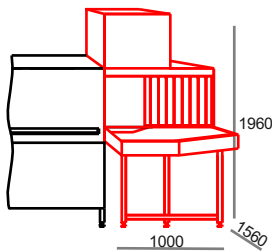

TC180 -AS Blower Dryer on 180° exit curve without motor

The dryer is fitted on a 180° mechanized curve to optimize working space in the washing area.

Module length	1000 x 1560 mm
Dryer fan power input	0,42 kW
Dryer heaters	6 kW
Sensible Capacity	8,2 kW
Latent Capacity	8,6 kW

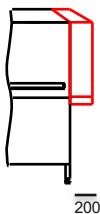

Splash Shield

The inlet/exit splash shield prevents splashing of water to the exterior of the machine. Optional collars for direct extraction.

Module length	200 mm
---------------------	--------

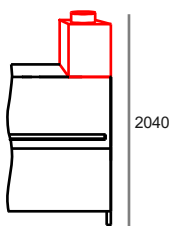

RC - Heat Recovery Unit

Fitted on the rinse section, it enables the machine to be connected to cold water, which is pre-heated and transferred to the rinse booster.

Total connection load becomes (cold water connection)	29,03 kW
Fan power input	0,047 kW
Sensible Capacity	3,4 kW
Latent Capacity	1,7 kW
Single point air extraction	

Options

EOR - EMERGENCY OVERRIDE - Key activated electromechanical emergency function. If an electronic malfunction occurs, the EOR ensures the machine drive system, wash pumps and heating elements continue to operate so you can organize servicing at a time that is most convenient for your operation.

APRS Automatic Proportional Rinse System (Autotimer Automatic Reset included)

Patented system which allows to reduce up to 30% dishwasher consumptions adapting automatically the water, energy and chemicals according to the work load.

Autotimer Automatic Reset

The timer-operated wash cycle enables the pumps to be stopped when there are no racks inside the machine. The machine automatically starts to operate again when new rack is loaded. This solution achieves considerable energy savings.

Central Drain

Any single tank drain is connected together in a central drain.

HPS EASY

A dedicated display enables the operators to keep a daily check on water and energy consumption and to be advised on any operational default.

HPS EASY PLUS

To store HACCP data on internal memory and copy them on a USB memory stick.

RAH Rinse Aid Homogenizer

It uniformly mixes rinse water and rinse agent. Reducing rinse aid consumption by 70%.

RCD Rinse Control Device

It combines an atmospheric booster and a rinse booster pump and ensures at a constant temperature throughout the cycle.

Sanitizing System

In each prewash, wash or rinse area, arms with adjustable nozzles are aimed at internal surfaces to guarantee maximum hygiene.

Rinse Aid Injector

Liquid Detergent Injector

Special voltages

230V 1~ 50 Hz
230V 1~ 60 Hz
230V 3~ 50 Hz
230V 3~ 60 Hz
440V 3~ 60 Hz
480V 3~ 60 Hz

Marine execution

Steam Heated Execution

Unit Connection load 1,03 kW
Steam Consumption72,4 0 kg/h
Saturated dry steam0,5 – 1,5 bar

*Installed load and steam consumption may vary from the accessories and options selected.

Installation drawing

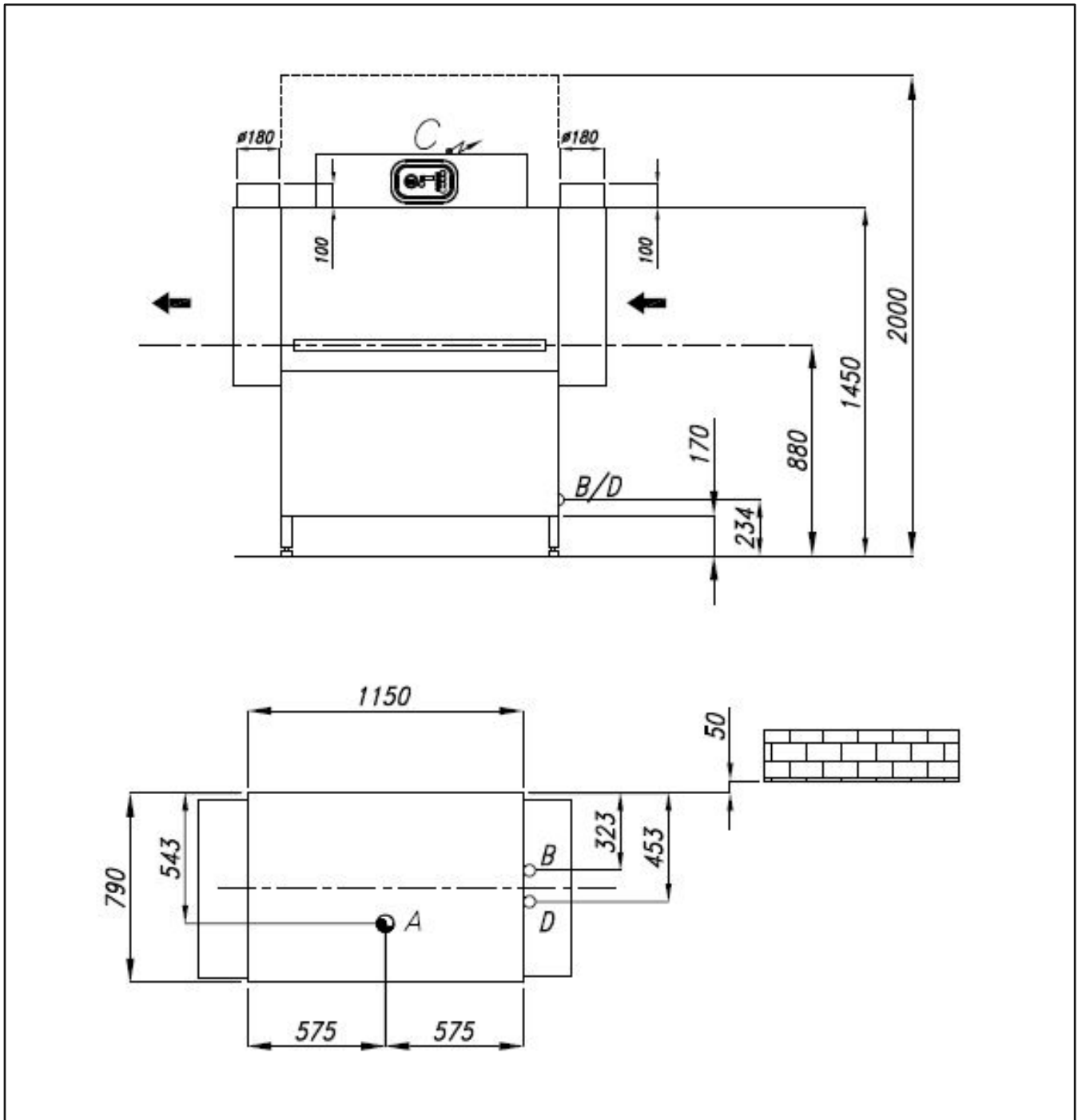

Feeding direction: left / right – right / left

The drawing refers to the standard machine with inlet / exit splash shield and collars.

Please enquire for the installation drawing relevant to the configuration selected.