

EKF 423 NM

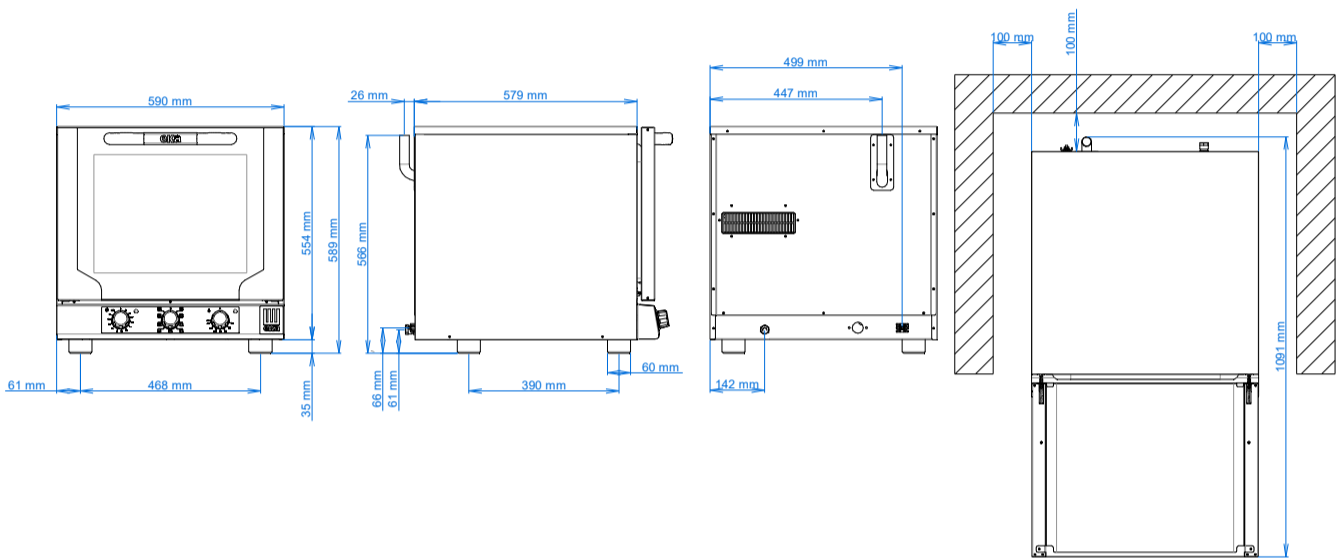

ELECTRIC CONVECTION OVEN WITH MULTIFUNCTION



DIMENSIONAL FEATURES

Oven dimensions (WxDxH mm)	590	709	589
Oven weight (kg)	36,4		
Distance between rack rails (mm)	74		

ELECTRICAL FEATURES

Power supply (kW)	2,6
Frequency (Hz)	50/60
Voltage (Volt)	AC 220/230
N° of motors	1 Unidirectional
Boiler	/
Protection against water	IPX4

FUNCTIONAL FEATURES

Power	Electricity
Capacity	N° 4 trays/grids 429x345 mm
Type of cooking	Ventilated
Steam	Indirect with button
Cooking chamber	AISI 430 Stainless steel
Temperature	100 - 260 °C
Temperature control	Thermostat
Control panel	Electromechanic - Lower side
N° of programs	/
Programmable cooking steps	/
Pre-heating temperature	/
Pre-heating function	/
Door	Tilt door Ventilated Inspectionable glass
Modularity	Available

EQUIPMENT

Cardboard box dimensions (WxDxH mm)	650	760	600
Aluminium tray 429x345	4 pcs (cod. KV7)		
Lateral supports	1 right + 1 left		
Cable	Single-phase [3G 1,5]-L=1600 mm		